

INSTRUCTIONS:

Caster Installation

PPN# 00104

[Retain for future reference.]

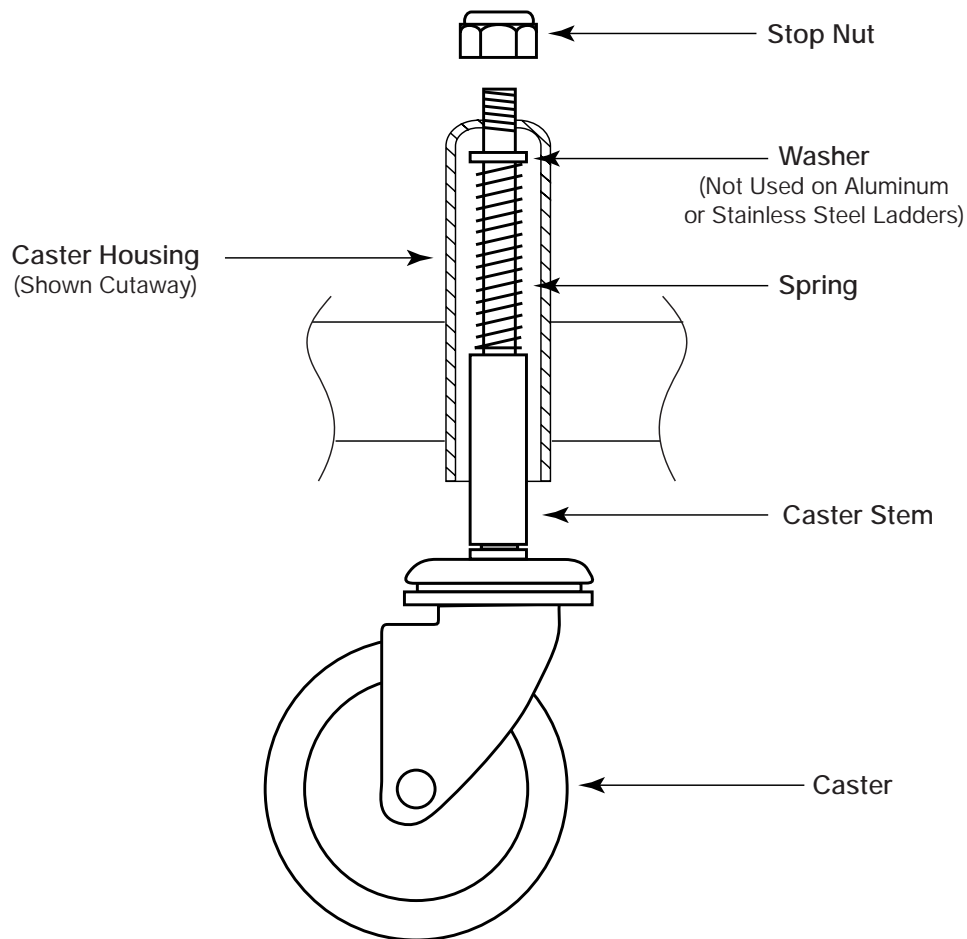

Steps For Assembly

1. Install **spring** and **washer** over the caster stem as shown above.
2. Insert **caster stem** into the **caster housing**.
3. Screw on the **stop nut** so that 2 threads of the stem appear above nut (Do not overtighten).
4. Before using ladder, be sure all 4 **rubber crutch tips** are installed on the legs of the ladder and are in good condition.
5. Understand and follow all usage guidelines and heed all cautions and warnings.



EGA PRODUCTS, INC. *Manufacturers of material handling and storage equipment*

Wisconsin Manufacturing: P.O. Box 366 • 4275 N. 127th St. • Brookfield, WI 53008-0366

North Carolina Manufacturing: S. Iredell Industrial Park • 208 McKenzie Rd. • Mooresville, NC 28115

Phone: 262-781-7899 Toll Free: 800-937-3427 Website: www.egaproducts.com